



US 20190371866A1

(19) **United States**

(12) **Patent Application Publication**

KIM et al.

(10) **Pub. No.: US 2019/0371866 A1**

(43) **Pub. Date: Dec. 5, 2019**

(54) **DISPLAY DEVICE**

G02B 3/00 (2006.01)

H01L 51/52 (2006.01)

(71) Applicant: **SAMSUNG ELECTRONICS CO., LTD.**, Suwon-si (KR)

(52) **U.S. Cl.**

CPC **H01L 27/322** (2013.01); **G02B 5/201** (2013.01); **H01L 2251/5369** (2013.01); **H01L 51/5275** (2013.01); **H01L 51/5253** (2013.01); **G02B 3/00** (2013.01)

(72) Inventors: **Tae Gon KIM**, Hwaseong-si (KR);
Sung Hun LEE, Hwaseong-si (KR);
Shin Ae JUN, Seongnam-si (KR);
Deukseok CHUNG, Yongin-si (KR)

(57) **ABSTRACT**

A display device includes an organic emission layer in which a first pixel area, a second pixel area and a third pixel area are defined, a color filter layer disposed on the organic emission layer and including first to third color filters overlapping the first to third pixel areas, respectively, where the first to third color filters emit first light to third light, respectively, a first optical filter layer disposed on the color filter layer and which transmits at least one of the first light and the second light and reflects or absorbs the third light, and a light-focusing layer disposed between the color filter layer and the organic emission layer and including first to third light-focusing parts overlapping the first to third pixel areas, respectively, where at least one of the first to third color filters includes quantum dots.

(21) Appl. No.: **16/424,729**

(22) Filed: **May 29, 2019**

(30) **Foreign Application Priority Data**

May 29, 2018 (KR) 10-2018-0061208

Publication Classification

(51) **Int. Cl.**

H01L 27/32 (2006.01)

G02B 5/20 (2006.01)

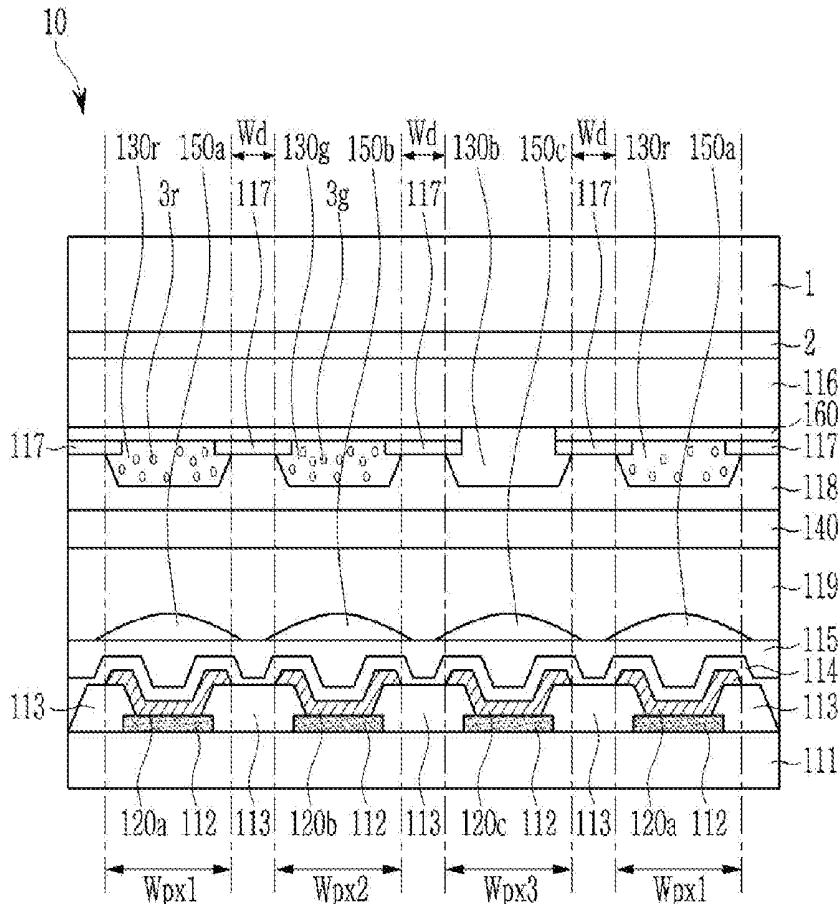
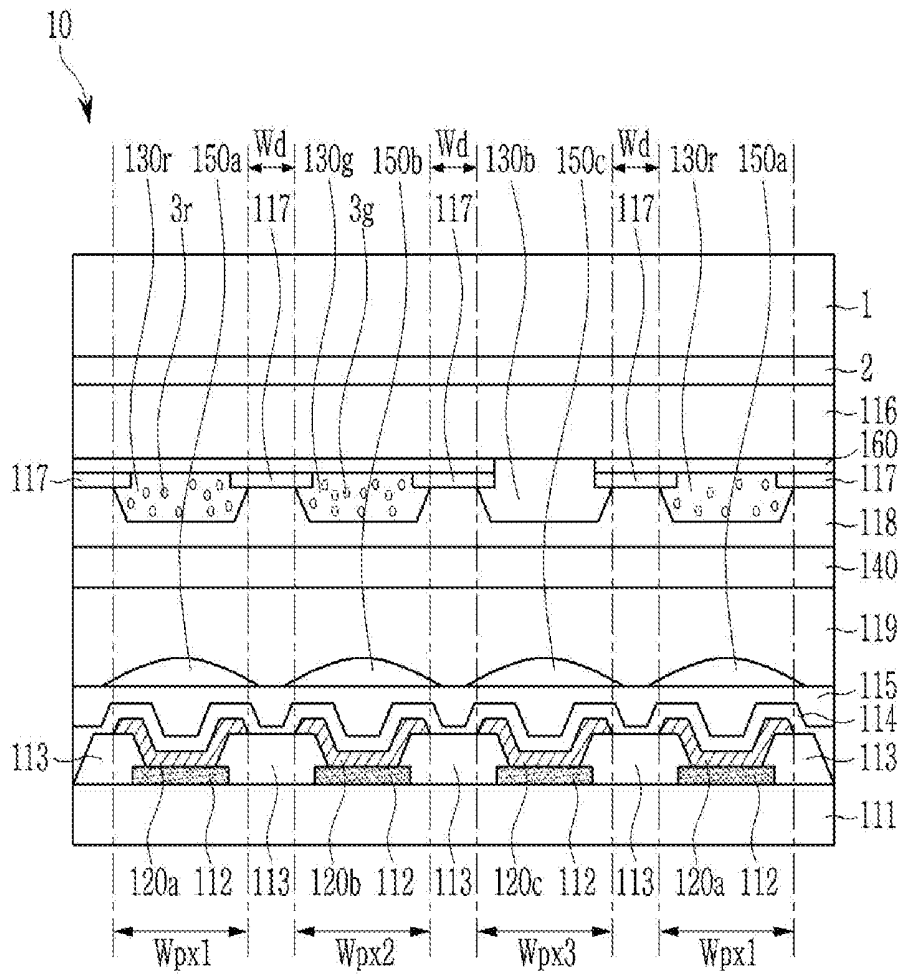

FIG. 1



$$3 \begin{cases} 3r \\ 3g \end{cases} \quad 120 \begin{cases} 120a \\ 120b \\ 120c \end{cases} \quad 130 \begin{cases} 130r \\ 130g \\ 130b \end{cases} \quad 150 \begin{cases} 150a \\ 150b \\ 150c \end{cases}$$

FIG. 2

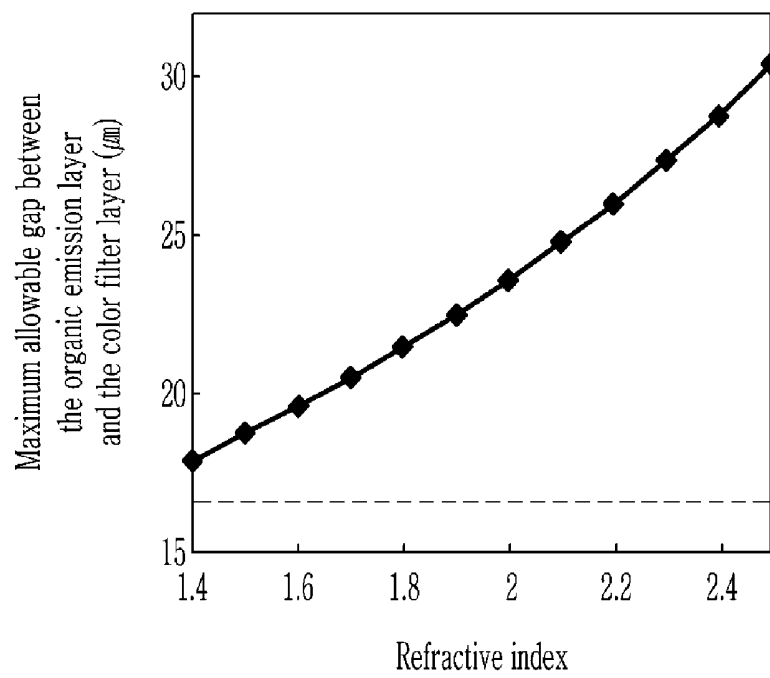

FIG. 3

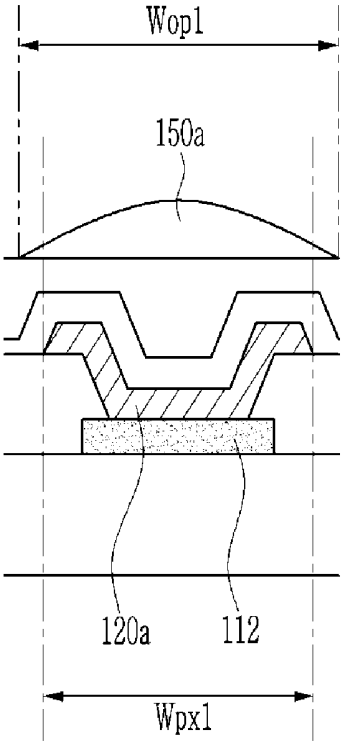

FIG. 4

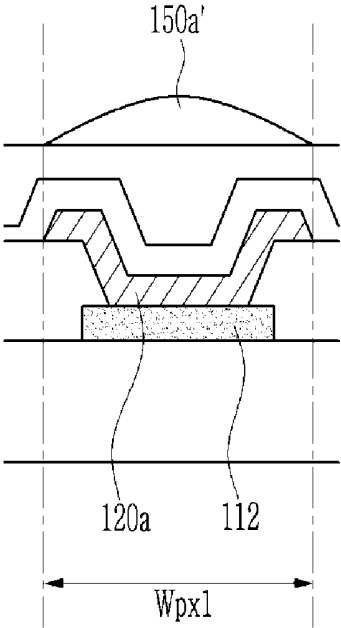

FIG. 5

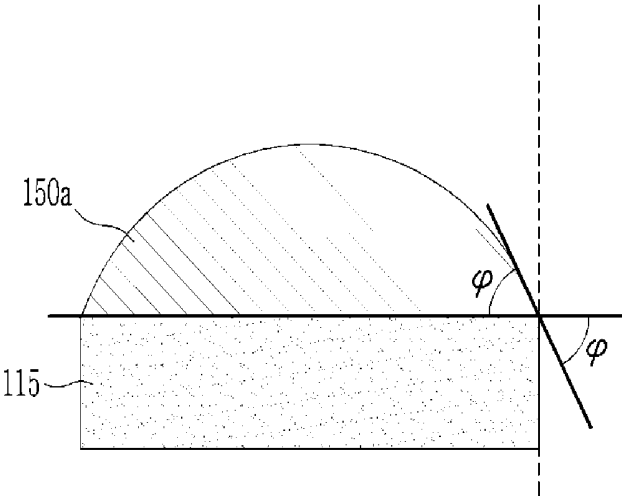

FIG. 6

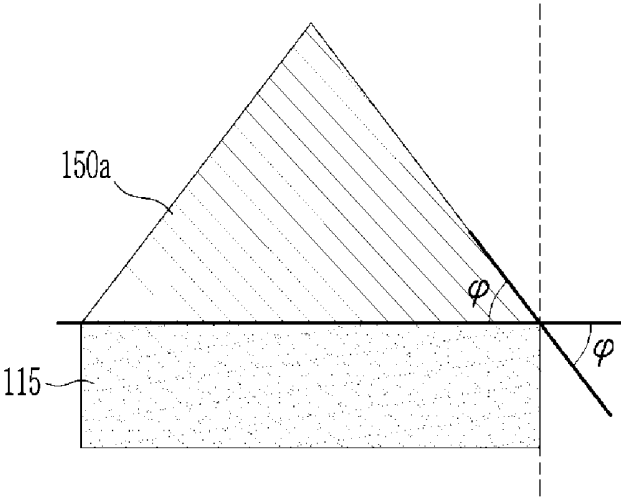

FIG. 7

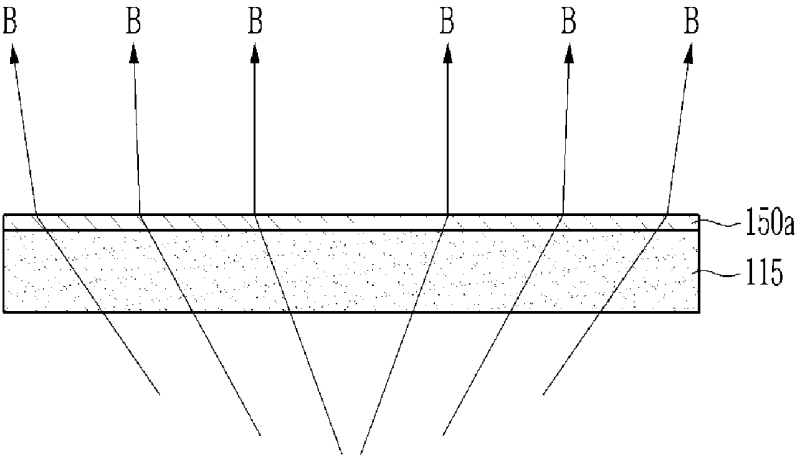

FIG. 8

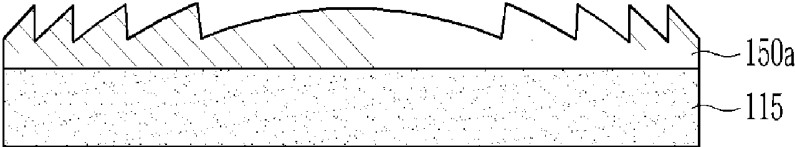

FIG. 9

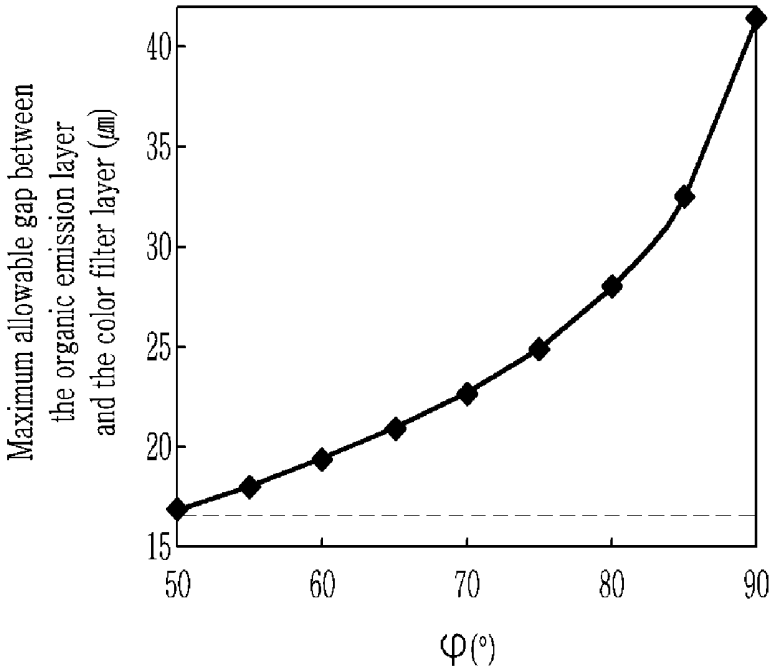

FIG. 10

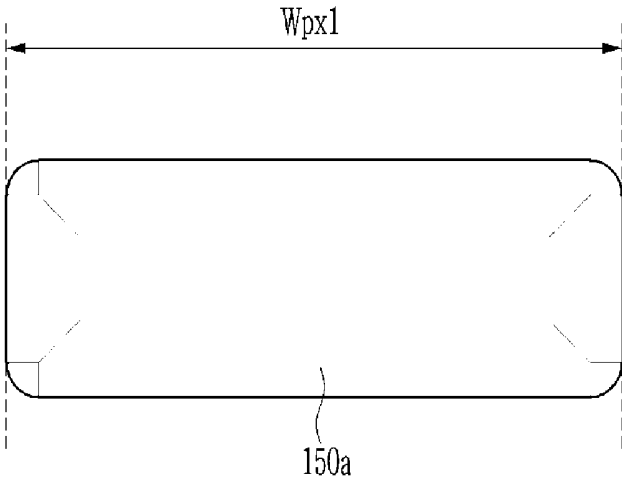

FIG. 11

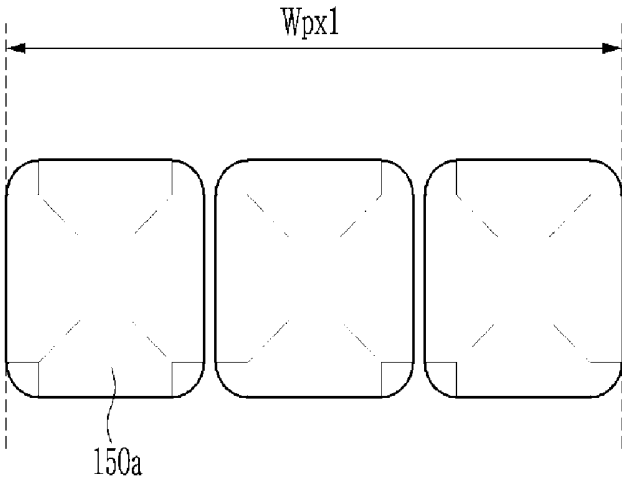

FIG. 12

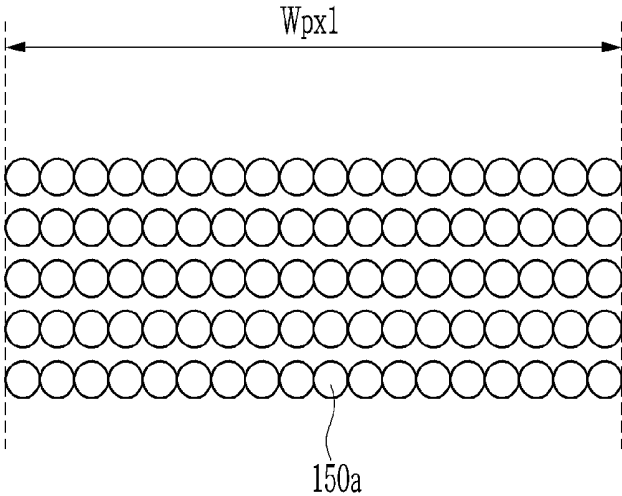

FIG. 13

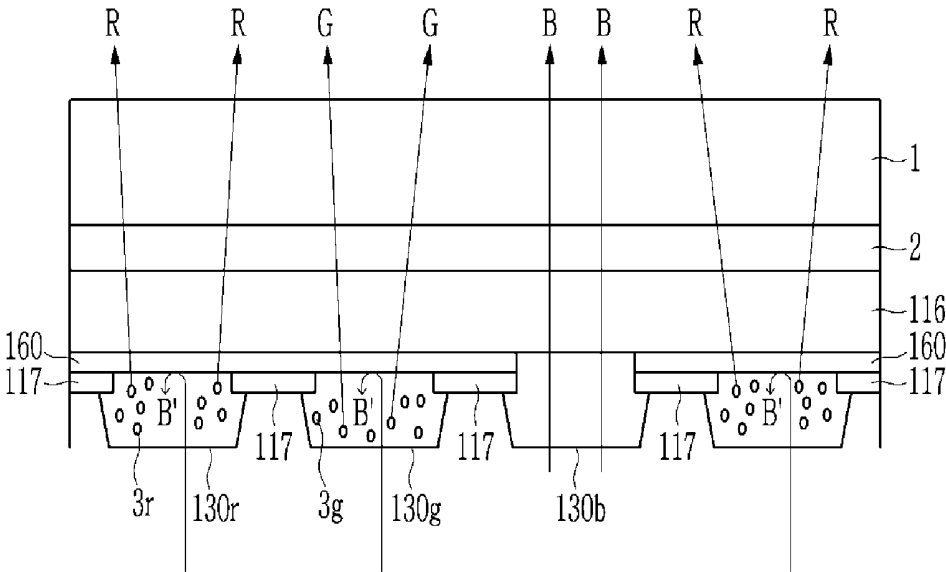
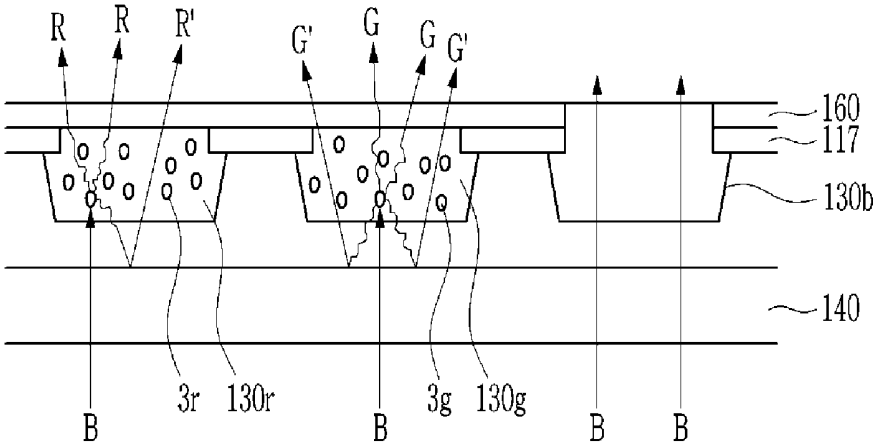

FIG. 14



DISPLAY DEVICE

CROSS-REFERENCE TO RELATED APPLICATION

[0001] This application claims priority to Korean Patent Application No. 10-2018-0061208, filed on May 29, 2018, and all the benefits accruing therefrom under 35 U.S.C. § 119, the content of which in its entirety is herein incorporated by reference.

BACKGROUND

1. Field

[0002] The disclosure relates to a display device for displaying an image.

2. Description of the Related Art

[0003] As a display device, a liquid crystal display, a plasma display device, an organic light emitting display or the like is currently commercially available, and such a display device may be driven with pixels, each of which emits one of red light, green light, blue light and/or white light, or by passing light emitted by a light source through a color filter to express colors corresponded to the pixels.

[0004] In a case of a display device including pixels that individually emit one of primary color lights, a high color purity enough to provide high image quality may be achieved, but a process difficulty for manufacturing in a large scale may be high since each pixel is formed with different materials having different characteristics from each other.

[0005] On the other hand, in a case of a display device in which light from the light source passes through color filters, manufacturing in a large scale may be effectively achieved, but a luminance and a color purity may be deteriorated since the emitted light may have a relatively wide full width at half maximum ("FWHM") when passed through the color filters by which light is absorbed and energy loss occurs.

SUMMARY

[0006] An embodiment provides a display device with reduced energy loss of emitted light and for providing high color purity and color reproducibility and being easily applicable even for a large-scale process.

[0007] According to an embodiment, a display device includes an organic emission layer in which a first pixel area, a second pixel area, and a third pixel area are defined; a color filter layer disposed on the organic emission layer, where the color filter layer includes first to third color filters overlapping the first to third pixel areas, respectively, and emits first light to third light, respectively, which are different from one another; a first optical filter layer disposed on the color filter layer, where the first optical filter transmits at least one of the first light and the second light and reflects or absorbs the third light; and a light-focusing layer disposed between the color filter layer and the organic emission layer, where the light-focusing layer includes first to third light-focusing parts overlapping the first to third pixel areas, respectively, where at least one of the first to third color filters includes quantum dots.

[0008] In an embodiment, the first optical filter layer may block light having a wavelength less than or equal to about 500 nanometers (nm).

[0009] In an embodiment, the first optical filter layer may be disposed to overlap at least one of the first pixel area and the second pixel area.

[0010] In an embodiment, the first optical filter layer may be integrally formed as a single unitary unit, and an opening may be defined in the first optical filter at a position overlapping the third pixel area.

[0011] In an embodiment, a refractive index of the light-focusing layer may be in a range from about 1.4 to about 2.5.

[0012] In an embodiment, a gap between the organic emission layer and the color filter layer may be in a range from about 5 micrometers (μm) to about 100 μm .

[0013] In an embodiment, each of the first to third light-focusing parts may include a convex lens, a micro-prism, a planar lens, a Fresnel lens, a metamaterial, or a combination thereof.

[0014] In an embodiment, at least one of the first to third light-focusing parts may include a convex lens, and a tilting angle of the convex lens may be in a range from about 30 degrees to about 90 degrees.

[0015] In an embodiment, at least one of the first to third light-focusing parts may include a micro-prism and a tilting angle of the micro-prism may be in a range from about 20 degrees to about 80 degrees.

[0016] In an embodiment, a width of each of the first to third light-focusing parts may be larger than a width of a corresponding one of the first to third pixel areas.

[0017] In an embodiment, at least two of each of the first to third light-focusing parts may be disposed to overlap a corresponding pixel area.

[0018] In an embodiment, each of the first to third pixel areas of the organic emission layer may emit the first light.

[0019] In an embodiment, a width of each of the first to third color filters may be the same as a width of a corresponding one of the first to third pixel areas.

[0020] In an embodiment, the display device may further include a second optical filter layer disposed between the color filter layer and the organic emission layer, where the second optical filter layer transmits the third light and reflects at least one of the first light and the second light.

[0021] In an embodiment, the second optical filter layer may reflect light having a wavelength greater than about 500 nm.

[0022] In an embodiment, the display device may further include a sealing layer disposed between the second optical filter layer and the light-focusing layer and having a refractive index lower than a refractive index of the light-focusing layer.

[0023] In an embodiment, the first light may be a red light, the second light may be a green light, and the third light may be a blue light.

[0024] In such an embodiment of a display device, the energy loss of emitted light is minimized, color purity and color reproducibility are improved, and such an embodiment of a display device is easily applicable even for a large-scale process.

BRIEF DESCRIPTION OF THE DRAWINGS

[0025] These and/or other features of the invention will become apparent and more readily appreciated from the following description of the exemplary embodiments, taken in conjunction with the accompanying drawings, in which:

[0026] FIG. 1 is a cross-sectional view of a display device according to an embodiment;

[0027] FIG. 2 shows a change of maximum allowable gap of between an organic emission layer and a color filter layer depending upon changing a refractive index of a light-focusing layer in a display device according to an embodiment;

[0028] FIGS. 3 and 4 are cross-sectional views showing a width relationship between a light-focusing part and a pixel area in a display device according to an embodiment, respectively;

[0029] FIGS. 5 to 8 are views showing a variety of shape examples of a light-focusing part according to an embodiment, respectively;

[0030] FIG. 9 shows a change of a maximum allowable gap of between an organic emission layer and a color filter layer depending upon changing a tilting angle of a light-focusing layer in a display device according to an embodiment;

[0031] FIGS. 10 to 12 are views showing a variety of disposition relationships in a pixel area of a light-focusing part according to an embodiment, respectively;

[0032] FIG. 13 is a cross-sectional view showing a function of a first optical filter layer in a display device according to an embodiment; and

[0033] FIG. 14 is a cross-sectional view showing a function of a second optical filter layer in a display device according to an embodiment.

DETAILED DESCRIPTION

[0034] The invention now will be described more fully hereinafter with reference to the accompanying drawings, in which various embodiments are shown. This invention may, however, be embodied in many different forms, and should not be construed as limited to the embodiments set forth herein. Rather, these embodiments are provided so that this disclosure will be thorough and complete, and will fully convey the scope of the invention to those skilled in the art. Like reference numerals refer to like elements throughout.

[0035] In the drawings, the thickness of layers, films, panels, regions, etc., are exaggerated for clarity. It will be understood that when an element such as a layer, film, region, or substrate is referred to as being “on” another element, it can be directly on the other element or intervening elements may also be present. In contrast, when an element is referred to as being “directly on” another element, there are no intervening elements present.

[0036] It will be understood that, although the terms “first,” “second,” “third” etc. may be used herein to describe various elements, components, regions, layers and/or sections, these elements, components, regions, layers and/or sections should not be limited by these terms. These terms are only used to distinguish one element, component, region, layer or section from another element, component, region, layer or section. Thus, “a first element,” “component,” “region,” “layer” or “section” discussed below could be termed a second element, component, region, layer or section without departing from the teachings herein.

[0037] The terminology used herein is for the purpose of describing particular embodiments only and is not intended to be limiting. As used herein, the singular forms “a,” “an,” and “the” are intended to include the plural forms, including “at least one,” unless the content clearly indicates otherwise. “or” means “and/or.” “At least A and B” means “A and/or B.” As used herein, the term “and/or” includes any and all combinations of one or more of the associated listed items.

It will be further understood that the terms “comprises” and/or “comprising,” or “includes” and/or “including” when used in this specification, specify the presence of stated features, regions, integers, steps, operations, elements, and/or components, but do not preclude the presence or addition of one or more other features, regions, integers, steps, operations, elements, components, and/or groups thereof.

[0038] Unless otherwise defined, all terms (including technical and scientific terms) used herein have the same meaning as generally understood by those skilled in the art. Terms as defined in a commonly used dictionary should be construed as having the same meaning as in an associated technical context, and unless defined apparently in the description, the terms are not ideally or excessively construed as having formal meaning.

[0039] Exemplary embodiments are described herein with reference to cross section illustrations that are schematic illustrations of idealized embodiments. As such, variations from the shapes of the illustrations as a result, for example, of manufacturing techniques and/or tolerances, are to be expected. Thus, embodiments described herein should not be construed as limited to the particular shapes of regions as illustrated herein but are to include deviations in shapes that result, for example, from manufacturing. For example, a region illustrated or described as flat may, typically, have rough and/or nonlinear features. Moreover, sharp angles that are illustrated may be rounded. Thus, the regions illustrated in the figures are schematic in nature and their shapes are not intended to illustrate the precise shape of a region and are not intended to limit the scope of the claims.

[0040] Hereinafter, embodiments of the invention will be described in detail with reference to the accompanying drawings.

[0041] A structure of an embodiment of a display device 10 will be described referring to FIG. 1.

[0042] FIG. 1 is a cross-sectional view of a display device according to an embodiment.

[0043] Referring to FIG. 1, an embodiment of the display device 10 includes a first substrate 111, a plurality of pixel electrodes 112 disposed on the first substrate 111, a pixel define layer 113 disposed between adjacent pixel electrodes 112, and an organic emission layer 120 disposed on each of the pixel electrodes 112, a common electrode 114 disposed on the organic emission layer 120, a first planarization layer 115 disposed on the common electrode 114, a light-focusing (or light-condensing) layer 150 disposed on first planarization layer 115, a sealing layer 119 disposed on the light-focusing layer 150, a second optical filter layer 140 disposed on the sealing layer 119, a second planarization layer 118 disposed on the second optical filter layer 140, a color filter layer 130 disposed on the second planarization layer 118 and including quantum dots 3, and a second substrate 116 disposed on the color filter layer 130, a first optical filter layer 160 disposed on the color filter layer 130, and an adhesion layer 2 and a cover layer 1 disposed on the second substrate 116.

[0044] In such an embodiment, the display device 10 includes the organic emission layer 120 and the color filter layer 130 including the quantum dots 3. In such an embodiment, the organic emission layer 120 provides or emits light to the color filter layer 130, and the provided light is supplied to quantum dots 3 in the color filter layer 130. As the result, light emitted to the outside of the display device 10 through the organic emission layer 120 and the color filter layer 130

may include light which is converted by the quantum dots **3** to have a wavelength in a predetermined wavelength region.

[0045] The quantum dots **3** have a discontinuous energy band gap by the quantum confinement effect to convert incident light to light in a predetermined wavelength and to radiate the converted light. Particularly, the quantum dots **3** may control to narrow a full width at half maximum (“FWHM”) of a light-emitting wavelength spectrum in several tens nanometers, e.g., less than or equal to about 50 nanometers (nm), less than or equal to about 40 nm, or less than or equal to about 30 nm. Thus, in such an embodiment, the display device **10** may display an image with improved color purity and improved color reproducibility using the quantum dots **3**.

[0046] In an embodiment, the display device **10** may be driven in a top-emission that light supplied from the organic emission layer **120** is emitted to the outside through the color filter layer **130**. The driving system of such a top-emission type is more desirable than a bottom-emission type in a view of an aperture ratio of each pixel area. Accordingly, in an embodiment, the display device **10** may show a high luminance image using the top-emission.

[0047] In such an embodiment of the display device **10**, a first panel including the organic emission layer **120** may be attached to a second panel including the color filter layer **130** after fabricating each of the first and second panels since the process temperature of the color filter layer **130** including quantum dots **3** is different from the temperature of forming the organic emission layer **120**, unlike a conventional color filter.

[0048] Thus, hereinafter, constituent elements included in the first panel and constituent elements included in the second panel will be sequentially described in detail.

[0049] According to an embodiment, as shown in FIG. 1, the first panel of the display device **10** has a structure where the first substrate **111**, the pixel electrode **112**, the pixel define layer **113**, the organic emission layer **120**, the common electrode **114**, the first planarization layer **115**, the light-focusing layer **150**, and a sealing layer **119** are stacked sequentially one on another.

[0050] The first substrate **111** may include an insulating material and may have flexibility. In one embodiment, for example, the first substrate **111** may include or be formed of at least one selected from glass, quartz and ceramic, or may be a flexible substrate including or made of a plastic. The first substrate **111** may include or be made of a polymer material such as polyimide (“PI”), poly carbonate (“PC”), polyether sulfone (“PES”), polyethylene terephthalate (“PET”), polyethylene naphthalate (“PEN”), polyarylate (“PAR”), a fiber glass reinforced plastic (“FRP”), and the like. The first substrate **111** may be transparent, semi-transparent, or opaque.

[0051] The pixel electrode **112** may function as an anode of the display device **10**. The pixel electrode **112** may include or be formed of a transparent conductive material such as indium tin oxide (“ITO”) or indium zinc oxide (“IZO”), for example. The pixel electrode **112** may include or be formed of a material having a light-blocking properties such as gold (Au), platinum (Pt), nickel (Ni), tungsten (W), chromium (Cr), molybdenum (Mo), iron (Fe), cobalt (Co), copper (Cu), palladium (Pd), titanium (Ti), and the like. Alternatively, the pixel electrode **112** may have a two-

layered structure where the transparent conductive material and the material having light-blocking properties are stacked sequentially one on another.

[0052] In an embodiment, although not shown in FIG. 1, a line layer including a thin film transistor or the like is disposed on the first substrate **111**. The line layer may further include a gate line, a sustain voltage line, a gate insulating layer, a data line, a source electrode, a drain electrode, a semiconductor, a protective layer, or the like. The detail structure of the line layer may be variously modified.

[0053] The gate line and the sustain voltage line are electrically separated or insulated from each other, and the data line is insulated and crossing the gate line and the sustain voltage line. The gate electrode, the source electrode and the drain electrode may define a control terminal, an input terminal, and an output terminal of the thin film transistor, respectively. The drain electrode is electrically connected to the pixel electrode **112**.

[0054] Between two adjacent pixel electrodes **112**, a pixel define layer **113** overlapping a terminal end of the pixel electrode **112** to divide the pixel electrode **112** into a pixel unit. The pixel define layer **113** is an insulation layer which may electrically block or insulated the at least two pixel electrodes **112** from each other.

[0055] The pixel define layer **113** covers a part of the upper surface of the pixel electrode **112**, and the remaining region of the pixel electrode **112** where is not covered by the pixel define layer **113** may defined an opening. An organic emission layer **120**, which will be described later, may be disposed on the region defined by the opening.

[0056] The organic emission layer **120** defines each pixel area by the pixel electrode **112** and the pixel define layer **113**. In such an embodiment, one pixel area may be defined as an area where is formed with one organic emission unit layer which is contacted with one pixel electrode **112** divided by the pixel define layer **113**.

[0057] In one embodiment of the display device **10**, for example, the organic emission layer **120** may be defined as a first pixel area, a second pixel area, and a third pixel area, and each pixel area is spaced apart from each other with a predetermined interval W_d by the pixel define layer **113**. According to an embodiment, unit layers pertaining to the first to the third pixel areas in the organic emission layer **120** are defined as first to third organic emission layers **120a** to **120c**, respectively.

[0058] In FIG. 1, widths of the first to the third pixel areas are represented by “Wpx1”, “Wpx2”, and “Wpx3”, respectively. A width of each of the first to third pixel areas may be the same as a width of each of the first to the third organic emission layers **120a** to **120c**, respectively. Herein, the term “overlapping a pixel area” means being at a position overlapping an area of “Wpx1”, “Wpx2”, or “Wpx3” when viewed from a plan view in a thickness direction of the first substrate **111**.

[0059] In an embodiment, the organic emission layer **120** may emit a third light in visible light region or an ultraviolet (“UV”) region. In such an embodiment, each of the first to the third pixel areas of the organic emission layer **120** may emit the third light. In an embodiment, the third light may be a light having the highest energy in the visible light region, for example, may be a blue light.

[0060] As described above, when all pixel areas of the organic emission layer **120** are designed to emit a same light as each other, each pixel area of the organic emission layer

120 may be all formed of a same or similar material or may show same or similar properties. Thus, in such an embodiment, a process difficulty of forming the organic emission layer **120** may be lowered, such that the display device **10** may be easily applied for the large scale/large area process.

[0061] However, the organic emission layer **120** is not limited thereto, but alternatively, the organic emission layer **120** may be designed to emit at least two different lights from each other.

[0062] The organic emission layer **120** includes an organic emission unit layer in each pixel area, and the each organic emission unit layer may further include an auxiliary layer (e.g., hole injection layer (“HIL”), hole transport layer (“HTL”), electron transport layer (“ETL”), etc.) besides the emission layer.

[0063] The common electrode **114** may function as a cathode of the display device **10**. The common electrode **114** may include or be formed of a transparent conductive material such as ITO or ZO. The common electrode **114** may be disposed on the organic emission layer **120** and may be integrally formed as a single unit covering all of the pixel areas.

[0064] A first planarization layer **115** is disposed on the common electrode **114**. The first planarization layer **115** may include an insulating material for providing electrical insulation with the common electrode **114**. The first planarization layer **115** may include a first layer disposed directly on a surface of the common electrode **114** and including an insulating material and a second layer disposed on the first layer and including an inorganic material and/or an organic material. In an embodiment, the first planarization layer **115** may have a structure of a first layer and a second layer or at least two layers of stacking an organic layer and an inorganic layer.

[0065] A light-focusing layer **150** is disposed on the upper planar surface of the first planarization layer **115**. The light-focusing layer **150** may include a first light-focusing part **150a** to a third light-focusing part **150c** disposed to overlap the first to the third pixel areas, respectively.

[0066] In an embodiment, the light-focusing layer **150** controls a path of the third light in a way such that the third light emitted from the organic emission layer **120** is entered into a color filter layer **130** which will be described later. In such an embodiment, each of the first to the third light-focusing parts **150a** to **150c** may control a path of light scattering toward an adjacent pixel area among the third light emitted from a corresponding one of the first to the third organic emission layers **120a** to **120c**, such that the light path is in a corresponding pixel area.

[0067] Accordingly, the light-focusing layer **150** prevents the third light emitted from each pixel area of the organic emission layer **120** from being scattered to the adjacent other pixel area, such that an unintended cross talk in first to third color filters **130r**, **130g**, and **130b** may be minimized. In such an embodiment, the display device **10** controls the light path of the third light through the light-focusing layer **150**, so that the display device **10** may display an image having a high color uniformity in each pixel.

[0068] In an embodiment, a refractive index of the light-focusing layer **150** may be variously determined depending upon a material, a refractive index, a thickness or the like of the first planarization layer **115** or the sealing layer **119**. In one embodiment, for example, the refractive index of the light-focusing layer **150** may be greater than or equal to

about 1.5, greater than or equal to about 1.6, greater than or equal to about 1.7, greater than or equal to about 1.8, greater than or equal to about 1.9, or greater than or equal to about 2.0, and, for example, less than or equal to about 2.8, less than or equal to about 2.7, less than or equal to about 2.6, less than or equal to about 2.5, or less than or equal to about 2.4. In one embodiment, for example, the refractive index of the light-focusing layer **150** may be in a range of about 1.5 to about 2.5, or about 1.5 to about 2.0.

[0069] When the light-focusing layer **150** has the refractive index within the range described above, the light-focusing layer **150** may show a relatively high refractive index than those of other constituent elements adjacent thereto, so the light-focusing layer **150** may not spread but focus the third light emitted from the organic emission layer **120** thereto.

[0070] In an embodiment, each of the first to the third light-focusing parts **150a** to **150c** in the light-focusing layer **150** may have a variety of sizes and/or shapes and/or disposition relationships.

[0071] FIG. 2 shows a change of a maximum allowable gap between the organic emission layer and the color filter layer depending upon changing a refractive index of the light-focusing layer in the display device according to an embodiment.

[0072] In FIG. 2, the changed value when applying the light-focusing layer **150** is expressed by a solid line graph, and the relationship when including no light-focusing layer is expressed by a dashed line graph (comparative). In a case of not including the light-focusing layer, as shown by the dashed line graph, the light path may be not controlled since the light-focusing layer **150** is not present, so the maximum allowable gap between the organic emission layer **120** and the color filter layer **130** is expressed by a constant value.

[0073] FIG. 2 shows graphs when the width of the pixel area is designated to be about 100 micrometers, and the interval between pixel areas (for example, shown by W_d in FIG. 1) is designated to be about 20 micrometers. In the solid line graph of FIG. 2 is obtained for a case where a convex lens having a tilting angle of about 65.4 degree is used as the light-focusing layer **150**, and light having an intensity of 30% relative to straight light having an incident angle of 0 degree, with a reference of an angle of light entered to the color filter, is controlled not to interfere an adjacent pixel, the maximum allowable gap between the organic emission layer **120** and the color filter layer **130** is shown in every refractive index of the light-focusing layer **150**.

[0074] Referring to FIG. 2, it is shown that the maximum allowable gap between the organic emission layer **120** and the color filter layer **130** is gradually increased as the refractive index of the light-focusing layer **150** is increased. However, considering tendencies to provide the higher integration, the ultra-thinner film, and the ultra-smaller size of the display device **10**, it is undesired to increase a gap between the organic emission layer **120** and the color filter layer **130** more than required.

[0075] Accordingly, when the refractive index of the light-focusing layer **150** is adjusted within the range described above, the light-focusing layer **150** may effectively focus a third light emitted from the organic emission layer **120** while not increasing the volume of the display more than required and with a relatively high refractive index in a relationship with the adjacent other constituent elements.

[0076] FIGS. 3 and 4 are cross-sectional views each showing a width relationship between the light-focusing part and the pixel area in the display device according to an embodiment.

[0077] In an embodiment of the display device 10, a width of each of the first to the third light-focusing parts 150a to 150c may be greater than or equal to a width of a corresponding one of the first to the third pixel areas (Wpx1 to Wpx3). For convenience of illustration and description, FIGS. 3 and 4 shows a width of the first pixel area with a width of the first light-focusing part 150a. In such an embodiment, as shown in FIG. 3, a width Wop1 of the first light-focusing part 150a is wider than the width Wpx1 of the first pixel area. Alternatively, as shown in FIG. 4, a width of a first light-focusing part 150a' may be substantially the same as the width Wpx1 of the first pixel area.

[0078] Each of the first to the third light-focusing parts 150a to 150c may have a width that is greater than or equal to each width (Wpx1 to Wpx3) of the first to the third pixel areas, such that the light-focusing layer 150 may effectively focus third light which is emitted near to both lateral sides of the organic emission layer 120 or is spread to the adjacent pixel area in a light path.

[0079] FIGS. 5 to 8 are views showing a shape of the light-focusing part according to various embodiment.

[0080] In embodiments, each of the first to the third light-focusing parts 150a to 150c may include a convex lens (referring to FIG. 5), a micro-prism (referring to FIG. 6), a planar lens (referring to FIG. 7), a Fresnel lens (referring to FIG. 8), a meta-material or a combination thereof. In one embodiment, for example, all of the first to the third light-focusing parts 150a to 150c include a convex lens as shown in FIG. 1. Alternatively, the first light-focusing part 150a includes a convex lens, and the second to the third light-focusing parts 150b and 150c may each include one selected from a micro-prism, a planar lens, a Fresnel lens and a meta-material.

[0081] In an embodiment, where at least one of the first to third light-focusing parts 150a to 150c includes a convex lens, a tilting angle (θ) of the convex lens may be variously determined depending upon a material, a refractive index, a thickness, and the like of the adjacent first planarization layer 115 or the sealing layer 119. In an embodiment, the tilting angle (θ) of the convex lens may be, for example, greater than or equal to about 40 degree, greater than or equal to about 50 degree, or greater than or equal to about 60 degree, and for example, less than or equal to about 90 degree or less than or equal to about 80 degree or, for example, about 50 degree to about 90 degree, or about 60 degrees to about 80 degrees.

[0082] In such an embodiment, referring to FIG. 5, for example, where the first light-focusing part 150a is formed with a convex lens, a tilting angle (θ) of the first light-focusing part 150a from the upper surface of the first planarization layer 115 is within the range described above.

[0083] In an alternative embodiment, where at least one of the first to the third light-focusing parts 150a to 150c includes a micro-prism, a tilting angle of the micro-prism may be variously determined depending upon a material, a refractive index, a thickness, or the like of the first planarization layer 115 or the sealing layer 119. In an embodiment, the tilting angle of the micro-prism may be, for example, greater than or equal to about 20 degrees, greater than or equal to about 30 degrees, greater than or equal to about 40

degrees, greater than or equal to about 50 degrees and, for example, less than about 90 degrees or less than or equal to about 80 degrees, or for example, about 20 degrees to about 80 degrees.

[0084] In such an embodiment, referring to FIG. 6, for example, where the first light-focusing part 150a is formed with a micro-prism, a tilting angle (θ) of the first light-focusing part 150a from the upper surface of the first planarization layer 115 may be within the range described above.

[0085] In such an embodiment, the tilting angle of the convex lens and/or the micro-prism is with the ranges described above, such that the convex lens and/or the micro-prism may effectively focus third light which is emitted near to the both lateral sides of the organic emission layer 120 and is spread to the adjacent pixel area in the light path although the gap between the organic emission layer 120 and the color filter layer 130 is somewhat increased.

[0086] FIG. 9 shows a change of a maximum allowable gap of between the organic emission layer and the color filter layer depending upon a tilting angle of the light-focusing part according to an embodiment.

[0087] In FIG. 9, similar to FIG. 2, the changing value of the case of employing the light-focusing layer 150 is represented by a solid line graph, and the relationship at a case that the light-focusing layer is not present is represented by a dashed line graph (comparative).

[0088] In addition, in FIG. 9, the graph is obtained for a case where a width of the pixel area is about 100 micrometers, and a gap between pixels is about 20 micrometers, which are the same as the conditions of FIG. 2.

[0089] Although the light-focusing layer 150 uses a convex lens having a refractive index of about 1.75 for the solid line graph of FIG. 9, a micro-lens having a refractive index of about 1.75 may obtain the same results. In addition, with reference to an angle of light entered to the color filter, the maximum allowable gap of between the organic emission layer and the color filter layer is shown in each tilting angle of the light-focusing layer when controlling the light having an intensity of 30% relative to the intensity of the straight light having an incident angle of 0 degree not to interfere the adjacent other pixel.

[0090] Referring to FIG. 9, it is shown that the maximum allowable gap between the organic emission layer 120 and the color filter layer 130 is also increased as the tilting angle of the light-focusing layer 150 is increased. However, as in FIG. 2, considering the tendency to provide a display device 10 with the higher integration, the ultra-thinner film, the down-size, it is not desired to increase a gap between the organic emission layer 120 and the color filter 130 layer more than required.

[0091] Accordingly, in an embodiment of the invention, the tilting angle of the light-focusing layer 150 is determined to be within the range described above, the light-focusing layer 150 may not spread and effectively focus third light emitted from the organic emission layer 120 while preventing undesired volume increase of the display device 10.

[0092] In an embodiment, where the light-focusing layer 150 includes a micro-prism, unlike the convex lens, the tilting angle may be at least less than about 90 degree. In such an embodiment, as the micro-prism has the higher tilting angle, the height is increased, so the tilting angle when using the micro-prism may be greater than the minimum tilting angle when using the convex lens, and, the

maximum tilting angle when using the microprism may be less than or equal to the maximum tilting angle when using the convex lens.

[0093] FIGS. 10 to 12 are views showing alignment relationships in the pixel area of the light-focusing part according to various embodiments.

[0094] In one embodiment, for example, the first to the third light-focusing parts 150a to 150c may be each disposed with any one selected from a planar lens, a micro-prism, a Fresnel lens, and a metamaterial, each overlapping each pixel area (referring to FIG. 10), but is not limited thereto. In an alternative embodiment, for example, at least two of the first to the third light-focusing parts 150a to 150c is disposed to overlap each pixel area (referring to FIGS. 11 and 12).

[0095] In an embodiment of the display device 10, a size and/or a shape and/or a disposition relationship of the of light-focusing layer 150 may be variously modified depending upon a material, a refractive index, a thickness or the like of the adjacent first planarization layer 115 or sealing layer 119, to allow the light-focusing layer 150 to efficiently focus the third light.

[0096] In an embodiment of the display device 10, referring back to FIG. 1, a sealing layer 119 is disposed on the light-focusing layer 150 to seal a first panel. The sealing layer 119 protects the organic emission layer 120 from extraneous moisture, oxygen and the like. The sealing layer 119 may include a getter absorbing moisture. Alternatively, the sealing layer 119 may include a getter layer including at least one getter.

[0097] In an embodiment, the sealing layer 119 may have a lower refractive index than the light-focusing layer 150, such that the light-focusing layer 150 may control a light path of the third light emitted from the organic emission layer 120 in a direction of focusing light.

[0098] The sealing layer 119 also functions as adhesive layer that attaches the first panel to a second panel, such that the first panel may be effectively attached to the second panel to function as a display device 10.

[0099] In an embodiment, the second panel of the display device 10 includes the second substrate 116, the adhesion layer 2 and the cover layer 1 disposed on the upper surface of the second substrate 116, the first optical filter layer 160 disposed under the second substrate 116, at least two light blocking members 117 directly under the first optical filter layer 160, the color filter layer 130 covering neighboring light blocking members 117, the second planarization layer 118 under the color filter layer 130, and the second optical filter layer 140 under the second planarization layer 118.

[0100] The second substrate 116 may include an insulating material and may have flexibility. In one embodiment, for example, the second substrate 116 may include or be formed of glass, quartz, and ceramic or may be a flexible substrate made of a plastic. The second substrate 116 may include or be made of a polymer material such as PI, PC, PES, PET, PEN, PAR, an FRP, and the like. In an embodiment, the second substrate 116 may be an optically transparent substrate since the second substrate 116 is disposed in a direction that light is emitted through the color filter layer 130.

[0101] A light blocking member 117 may be disposed in a position overlapping the pixel define layer 113 of the first panel. At least two light blocking members 117 are disposed with a predetermined interval, such that the first to the third color filters 130r, 130g, and 130b of the color filter layer 130

overlap the first to the third pixel areas, respectively. According to an embodiment, the light blocking member 117 is disposed directly under a first optical filter layer 160, but is not limited thereto. In one alternative embodiment, for example, the light blocking member 117 may be disposed directly under the second substrate 116 according to the disposition relationship of the first optical filter layer 160.

[0102] The light blocking member 117 may include or be made of a light-blocking material, for example, a material including a metal particle such as chromium (Cr), silver (Ag), molybdenum (Mo), nickel (Ni), titanium (Ti), tantalum (Ta), and the like, an oxide of the metal particle, or a combination thereof. The light blocking member 117 effectively prevents a light leakage phenomenon of the display device 10 and improves a contrast.

[0103] The color filter layer 130 is disposed between and to cover the adjacent light blocking members 117. The color filter layer 130 includes first to third color filters 130r, 130g, and 130b disposed in positions overlapping the first to the third pixel areas, respectively.

[0104] According to an embodiment, the first color filter 130r may emit a first light different from the third light, the second color filter 130g may emit a second light different from the third light, and the third color filter 130b may emit the third light. According to an embodiment, the first light may be a red light, the second light may be a green light, and the third light may be a blue light or a UV light.

[0105] However, an embodiment is not limited thereto, but a kind of the first light to the third light may be variously modified according to a kind of quantum dots 3, the used material of the organic emission layer 120, and the like.

[0106] In an embodiment, the color filter layer 130 may include quantum dots 3 for converting the third light supplied from the organic emission layer 120 to the first light and/or the second light and emitting the converted light. According to an embodiment, quantum dots 3 may include first quantum dots 3r included in the first color filter 130r and second quantum dots 3g included in the second color filter 130g.

[0107] According to an embodiment, the first and the second color filters 130r and 130g include the first and the second quantum dots 3r and 3g, respectively, and the first and the second quantum dots 3r and 3g may be obtained by coating first and second photosensitive compositions including a binder, a photopolymerizable monomer, a photoinitiator and a solvent on the first and the second pixel areas, respectively, as shown in FIG. 1, and curing the coated first and second photosensitive compositions.

[0108] In an embodiment, the first quantum dots 3r and the second quantum dots 3g may be formed of a same material as each other but may have different sizes from each other, so that the entered third light may be differently emitted as a first light and a second light which are different from each other.

[0109] In one embodiment, for example, the second quantum dots 3g may have a smaller size than the first quantum dots 3r, s to emit a green light having a center wavelength of about 530±5 nm, an FWHM from about 40 nm to about 60 nm, and a relatively high energy. In such an embodiment, the second quantum dots 3g has a larger size than the first quantum dots 3r to emit a red light having a center wavelength of about 625±5 nm, an FWHM from about 40 nm to about 60 nm, and a relatively low energy.

[0110] However, an embodiment is not limited thereto, but the first and the second quantum dots **3r** and **3g** may be formed of different materials from each other.

[0111] The quantum dots **3** may have at least one of shapes of quantum dots known in the art, and may not be particularly limited. The quantum dots **3** may have a spherical shape as shown in FIG. 1, or may be, for example, a pyramidal, multi-armed, or a cube nanoparticle, a nanotube, a nanowire, a nanofiber or a nanosheet.

[0112] In an embodiment, a material of the quantum dots **3** is not particularly limited and the quantum dots **3** may be known or commercially available. In one embodiment, for example, the quantum dots may include a Group II-VI compound, a Group III-V compound, a Group IV-VI compound, a Group IV compound, or a combination thereof.

[0113] The Group II-VI compound may be at least one selected from: a binary element compound selected from CdSe, CdTe, ZnS, ZnSe, ZnTe, ZnO, HgS, HgSe, HgTe, MgSe and MgS; a ternary element compound selected from CdSeS, CdSeTe, CdSTe, ZnSeS, ZnSeTe, ZnSTe, HgSeS, HgSeTe, HgSTe, CdZnS, CdZnSe, CdZnTe, CdHgS, CdHgSe, CdHgTe, HgZnS, HgZnSe, HgZnTe, MgZnSe and MgZnS; a quaternary element compound selected from HgZnTeS, CdZnSeS, CdZnSeTe, CdZnSTe, CdHgSeS, CdHgSeTe, CdHgSTe, HgZnSeS, HgZnSeTe and HgZnSTe, and a mixture thereof.

[0114] The Group III-V compound may be at least one selected from: a binary element compound selected from GaN, GaP, GaAs, GaSb, AlN, AlP, AlAs, AlSb, InN, InP, InAs and InSb, a ternary element compound selected from GaNP, GaNAs, GaNSb, GaPAs, GaPSb, AlNP, AlNAs, AlNSb, AlPAs, AlPSb, InNP, InNAs, InNSb, InPAs and InPSb, a quaternary element compound selected from GaAlNP, GaAlNAs, GaAlNSb, GaAlPAs, GaAlPSb, GaInNP, GaInNAs, GaInNSb, GaInPAs, GaInPSb, InAlNP, InAlNAs, InAlNSb, InAlPAs and InAlPSb, and a mixture thereof. The Group IV-VI compound may be at least one selected from: a binary element compound selected from SnS, SnSe, SnTe, PbS, PbSe and PbTe; a ternary element compound selected from SnSeS, SnSeTe, SnSTe, PbSeS, PbSeTe, PbSTe, SnPbS, SnPbSe and SnPbTe; a quaternary element compound selected from SnPbSSe, SnPbSeTe and SnPbSTe; and a mixture thereof.

[0115] The Group IV compound may be a single substance selected from Si and Ge, a binary element compound selected from SiC and SiGe, or a mixture thereof.

[0116] The binary element compound, the ternary element compound or the quaternary element compound of a particle respectively exist in a uniform concentration in a particle or in partially different concentrations in the same particle. The quantum dots **3** may have a core/shell structure where one quantum dot surrounds another quantum dot. The core and the shell may have a concentration gradient where the concentration of the element(s) of the shell decreases toward the core. In addition, the quantum dots **3** may have a single semiconductor nanocrystal core and multi-shells surrounding the core. Herein, the multi-layered shell structure has a structure of two or more shells and each shell may have a single composition or an alloy or may have a concentration gradient.

[0117] In addition, the quantum dots **3** have a material composition of the shell having a larger energy bandgap than that of the core, which may exhibit an effective quantum confinement effect. In such a multi-layered shell, an outer

shell may have a higher energy bandgap than an inner shell that is near to the core and the light converted by the quantum dots may be in an UV to infrared wavelength range.

[0118] The quantum dots **3** may have quantum efficiency of greater than or equal to about 10%, for example, greater than or equal to about 30%, greater than or equal to about 50%, greater than or equal to about 60%, greater than or equal to about 70%, or greater than or equal to about 90%.

[0119] According to an embodiment, the third color filter layer **130b** may be defined by a transparent body, so that the third light supplied from the organic emission layer **120** may be emitted as it is without being converted. In such an embodiment, the third color filter layer **130b** may not include quantum dots **3** unlike the first and the second color filters **130r** and **130g**. In such an embodiment, the transparent body may include a scattering inducer (not shown) which does not change a wavelength of the third light but only change a propagation direction thereof.

[0120] According to an embodiment, the first to the third color filters **130r**, **130g** and **130b** may have widths the same as the widths Wpx1, Wpx2 and Wpx3 of the first to the third pixel areas, respectively, such that an unintended cross talk in the first to the third color filters **130r**, **130g**, and **130b** is substantially minimized.

[0121] The second planarization layer **118** is disposed directly under the color filter layer **130**. The second planarization layer **118** may include a same material and/or have a same disposition structure as the first planarization layer **115**, or may include a different material from the first planarization layer **115**.

[0122] The second planarization layer **118** functions to planarize the lower surface of the color filter layer **130** to allow a second optical filter layer **140**, which will be described later, to be disposed or formed on a planar or flat surface. The second planarization layer **118** may include or be formed of an optically transparent material. According to an embodiment, the second planarization layer **118** may have an absorption rate, for light within a visible light region, of less than or equal to about 10%, for example, less than or equal to about 9%, less than or equal to about 8%, less than or equal to about 7%, less than or equal to about 6%, less than or equal to about 5%, less than or equal to about 4%, less than or equal to about 3%, less than or equal to about 2%, less than or equal to about 1%, or even about 0%.

[0123] However, the functions of the second planarization layer **118** are not limited thereto. In one alternative embodiment, for example, the second optical filter layer **140** is omitted from the display device **10**, and the second planarization layer **118** may be disposed to directly contact the sealing layer **119**. In such an embodiment, the second planarization layer **118** functions to sufficiently contact the second panel to the first panel without spacing from the upper surface and bubbles thereon.

[0124] Hereinafter, the first optical filter layer and the second optical filter layer according to an embodiment will be described in detail with references to FIGS. 13 and 14 in addition to FIG. 1.

[0125] FIG. 13 is a cross-sectional view showing a function of the first optical filter layer in the display device according to an embodiment.

[0126] Referring to FIGS. 1 and 13, an embodiment of the display device **10** may include a first optical filter layer **160** disposed between the second substrate **116** and the color

filter layer 130. In such an embodiment, the first optical filter layer 160 blocks at least a part of the third light.

[0127] The first optical filter layer 160 may be disposed directly under the second substrate 116. The first optical filter layer 160 may be disposed to overlap the first pixel area and the second pixel area.

[0128] According to an embodiment, the first optical filter layer 160 may be disposed on all positions overlapping each of the first and the second pixel areas.

[0129] In an embodiment, the first optical filter layer 160 may be integrally formed in a single unitary unit and disposed to overlap an entire bottom surface of the second substrate 116 except with a portion overlapping the third pixel area, as shown in FIG. 13. In such an embodiment, an opening is defined in the first optical filter layer 160 at a position overlapping the third pixel area. However, an embodiment is not limited to the disposition relationship.

[0130] In an embodiment, the color filter layer 130 is disposed on the first optical filter layer 160 to be positioned between the first optical filter layer 160 and the second optical filter layer 140, and a specific disposition relationship between the first optical filter layer 160 and the color filter layer 130, the light blocking member 117, and the second substrate 116 may be variously modified.

[0131] In one embodiment, for example, the first optical filter layer 160 may be disposed between the second substrate 116 and the adhesion layer 2, or the first optical filter layer 160 may be disposed between the light blocking member 117 and the color filter layer 130.

[0132] In an embodiment, the first optical filter layer 160 may be divided into portions not integrally formed with each other. In one embodiment, for example, the first optical filter layer 160 may include at least two portions spaced apart from each other and disposed to overlap the first and the second pixel areas, respectively.

[0133] The first optical filter layer 160 may block light in, for example, a predetermined wavelength region in the visible light region and may transmit light in the other wavelength regions. In one embodiment, for example, the first optical filter layer 160 may block blue light and may transmit light except the blue light. In one alternative embodiment, for example, the first optical filter layer 160 may transmit green light, red light, and/or yellow light which is a mixed light thereof.

[0134] The first optical filter layer 160 may substantially block (i.e. reflect or absorb), for example, a blue light having a wavelength less than or equal to about 500 nm, and may have a property to transmit a wavelength region between the remaining visible light wavelength region of greater than about 500 nm and less than or equal to about 700 nm.

[0135] In one embodiment, for example, the first optical filter layer 160 may have a light transmittance of greater than or equal to about 70%, greater than or equal to about 80%, greater than or equal to about 90%, or even about 100% for the other visible light having a wavelength greater than or equal to 500 nm and less than or equal to about 700 nm.

[0136] The first optical filter layer 160 may be a polymer thin film including a dye and/or a pigment for absorbing a wavelength to be blocked, and may absorb a blue light at greater than or equal to about 80%, greater than or equal to about 90%, greater than or equal to about 95%, but may have a light transmittance of greater than or equal to about 70%, greater than or equal to about 80%, greater than or equal to

about 90%, and even about 100% to the other visible light having a wavelength greater than about 500 nm and less than or equal to about 700 nm.

[0137] In an embodiment, the first optical filter layer 160 may substantially block a blue light having a wavelength less than or equal to about 500 nm by absorbing the same, and the first optical filter layer 160 may selectively transmit, for example, a green light or a red light. In such an embodiment, the first optical filter layer may include at least two portions disposed spaced apart from each other and disposed to overlap the first to the second pixel areas, respectively. In one embodiment, for example, a portion of the first optical filter layer that selectively transmits a red light may be disposed in a region overlapping the first pixel area, and another portion of the first optical filter layer that selectively transmits a green light may be disposed on a region overlapping the second pixel area.

[0138] The first optical filter layer 160 may include a reflective filter including a plurality of layers having different refractive indexes from each other as in the second optical filter layer 140. In one embodiment, for example, the first optical filter layer 160 may be formed by alternatively stacking two layers having different refractive indexes from each other, for example, by alternatively (and/or repeatedly) stacking a layer having a high refractive index and a layer having a low refractive index one on another.

[0139] As refractive index difference between the layer having a high refractive index and the layer having a low refractive index is higher, the first optical filter layer 160 has the higher selectivity to a wavelength.

[0140] A thickness and the stacked number of the layer having a high refractive index and the layer having a low refractive index may be determined according to a refractive index of each layer and a wavelength to be reflected. In one embodiment, for example, each layer having a high refractive index may have a thickness in a range of about 3 nm to about 300 nm, and each layer having a low refractive index may have a thickness in a range of about 3 nm to about 300 nm.

[0141] The total thickness of the first optical filter layer 160 may be, for example, in a range of about 3 nm to about 10000 nm, about 300 nm to about 10000 nm, or about 1000 nm to about 10000 nm. All layers having a high refractive index may have a same thickness as each other and may include a same material as each other or different materials from each other, and all layers having a low refractive index may have a same thickness as each other and may include a same material as each other or different materials from each other.

[0142] In an embodiment, the first optical filter layer 160 may be formed by binding a reflective filter, in which materials having different refractive indexes from each other are stacked, under an absorptive optical filter, which includes at least two layers alternatively stacked.

[0143] In an embodiment, as described above, the first optical filter layer 160 blocks a blue light among the visible light and transmits other lights except the blue light, for example, a green light, a red light, and/or a yellow light which is a mixed light thereof, so that the display device 10 may express an image having improved color purity and color reproducibility.

[0144] In an embodiment, as shown in FIG. 13, an adhesion layer 2 and a cover layer 1 may be substantially stacked on the second substrate 116.

[0145] The adhesion layer 2 may attach and fix the cover layer 1 and the first optical filter layer 160, and may include the various disclosed materials.

[0146] The cover layer 1 may function to protect inside constituent elements from the outside of the display device 10. The cover layer 1 may include, for example, an overcoat layer, a window layer or the like. But, an embodiment is not limited thereto, but the cover layer 1 and the adhesion layer 2 may be modified or omitted.

[0147] In an embodiment the display device 10, the second optical filter layer 140 may be formed directly under the second planarization layer 118 to provide a relatively planar surface, as shown in FIG. 1.

[0148] In an embodiment, the second optical filter layer 140 may include a monolayer having a low refractive index. In one embodiment, for example, the second optical filter layer 140 may be a transparent thin film having a refractive index of less than or equal to about 1.4, less than or equal to about 1.3, or less than or equal to about 1.2.

[0149] The second optical filter layer 140 having a low refractive index may include, for example, a porous silicon oxide, a porous organic material, a porous organic/inorganic composite, or a combination thereof.

[0150] In an embodiment, the second optical filter layer 140 may include a plurality of layers having different refractive indexes from each other. In one embodiment, for example, the second optical filter layer 140 may be formed by alternatively stacking two layers having different refractive indexes from each other, or may be formed by alternatively stacking a material having a high refractive index and a material having a low refractive index.

[0151] The layer having a high refractive index in the second optical filter layer 140 may include, for example, at least one selected from hafnium oxide, tantalum oxide, titanium oxide, zirconium oxide, magnesium oxide, cesium oxide, lanthanum oxide, indium oxide, niobium oxide, aluminum oxide, and silicon nitride, but not being limited thereto. In such an embodiment, the layer having a high refractive index in the second optical filter layer 140 may include another material having a higher refractive index than the layer having a low refractive index in the second optical filter layer 140.

[0152] The layer having a low refractive index in the second optical filter layer 140 may include, for example, a silicon oxide, but not being limited thereto. In such an embodiment, the layer having a low refractive index in the second optical filter layer 140 may include another material having a lower refractive index than the layer having a high refractive index in the second optical filter layer 140.

[0153] As the refractive index difference between the layer having a high refractive index and the layer having a low refractive index is the higher, the second optical filter layer 140 may have the higher selectivity to a wavelength.

[0154] In the second optical filter layer 140, each thickness of the layer having a high refractive index and the layer having a low refractive index and the stacked number thereof may be determined depending upon a refractive index of each layer and the wavelength to be reflected. In one embodiment, for example, each layer having a high refractive index in the second optical filter layer 140 may have a thickness in a range of about 3 nm to about 300 nm, and each layer having a low refractive index in the second optical filter layer 140 may have a thickness in a range of about 3 nm to about 300 nm. The total thickness of the

second optical filter layer 140 may be in a range of, for example, about 3 nm to about 10000 nm, about 300 nm to about 10000 nm, or about 1000 nm to about 10000 nm. Each of the layer having a high refractive index and the layer having a low refractive index in the second optical filter layer 140 may have a same thickness and material as each other or different thicknesses and materials from each other.

[0155] FIG. 14 is a cross-sectional view showing a function of the second optical filter layer in the display device according to an embodiment.

[0156] In an embodiment, the second optical filter layer 140 reflects at least a part R', G' of the first light R and the second light G and transmits at least a part of the third light B.

[0157] In such an embodiment, the second optical filter layer 140 may transmit only the third light B in a blue light wavelength region or a wavelength region of less than or equal to about 500 nm, as shown in FIG. 14, and light in a wavelength region of greater than about 500 nm, which is a green light G, a yellow light, a red light R or the like, may not be passed through the second optical filter layer 140 but be reflected G', R'. Thus, the reflected green and red lights G', R' may pass through the first and the second color filters 130r and 130g to be emitted to the outside of the display device 10.

[0158] The second optical filter layer 140 may reflect the light in a wavelength region of greater than about 500 nm with a reflectance of greater than or equal to about 70%, greater than or equal to about 80%, or greater than or equal to about 90%, or even about 100%.

[0159] In an embodiment, the second optical filter layer 140 may transmit the light in a wavelength region of less than or equal to about 500 nm with a transmittance of, for example, greater than or equal to about 90%, greater than or equal to about 92%, greater than or equal to about 94%, greater than or equal to about 96%, greater than or equal to about 98%, greater than or equal to about 99%, or even about 100%.

[0160] As quantum dots 3 isotropically radiate light, a part of the red light R and green light G emitted by the first and the second quantum dots 3r, 3g may be radiated toward a supplying direction of the third light when the third light is supplied to the first and the second quantum dots 3r, 3g. Accordingly, if an emitting direction of the red light R and the green light G converted by quantum dots 3 is not controlled, the light efficiency of the emitted light is unavoidably deteriorated.

[0161] However, an embodiment of the display device 10 transmits a blue light using the second optical filter layer 140 and reflects a red light and green light and emits the reflected red and green lights, such that light efficiency and luminance of the display device 10 may be improved.

[0162] In an embodiment of the display device 10, a gap between the organic emission layer 120 and the color filter layer 130 may be greater than or equal to about 5 micrometers, for example, greater than or equal to about 10 micrometers, greater than or equal to about 20 micrometers, greater than or equal to about 30 micrometers, and for example, less than or equal to 100 micrometers, less than or equal to about 50 micrometers, less than or equal to about 30 micrometers, or less than or equal to about 10 micrometers, or for example, about 5 micrometers to about 100 micrometers, or about 10 micrometers to about 100 micrometers.

[0163] In such an embodiment, the display device **10** may display an image having a higher luminance, color purity, and color reproducibility than a conventional display device in which an absorptive color filter layer is disposed on the organic emission layer. In such an embodiment, a second optical filter layer **140** having a thickness of several to several tens micrometers is used due to inherent characteristics of the quantum dots **3**. Accordingly, in an embodiment, where the display device **10** is a top emission type, the gap between the organic emission layer **120** and the color filter layer **130** in the display device **10** may be slightly increased or relatively larger when compared to the conventional display device.

[0164] In such an embodiment, the third light emitted from the pixel area may be further widely spread to be entered into the color filter layer **130** due to the increased gap between the organic emission layer **120**, such that the possibilities of a crosstalk occurrence between the adjacent color filters are increased.

[0165] Accordingly, in an embodiment of the display device **10**, a light path of the third light through the light-focusing layer **150** is controlled as described above, such that the crosstalk between the adjacent color filters may be minimized even when the gap between the organic emission layer **120** and the color filter layer **130** is increased.

[0166] Embodiments of the display device **10** are not limited thereto, but the light-focusing layer **150** may be omitted considering the refractive index relationship between the second optical filter layer **140** and the adjacent constituent elements or in a case of employing other optical constituent elements reflecting third light under the organic emission layer **120** to control the light path to the color filter layer **130**.

[0167] In an embodiment, as described above, the display device **10** converts the third light emitted from the organic emission layer **120** into first light and/or second light by quantum dots **3** included in the color filter layer **130**, so the display device **10** may display an image with improved color purity and color reproducibility.

[0168] In an embodiment, where the display device **10** is a top emission type, the display device **10** may further include a second optical filter layer **140** and/or a first optical filter layer **160** considering the inherent characteristics of quantum dots **3**, and may display an image with a high luminance.

[0169] In an embodiment of the display device **10**, all pixel regions of the organic emission layer **120** emit a same light, such that the process difficulty of forming the organic emission layer **120** may become substantially less. As the results, such an embodiment of the display device **10** may be effectively applied for the large scale/large area process.

[0170] While the invention has been particularly shown and described with reference to exemplary embodiments thereof, it will be understood by those of ordinary skill in the art that various changes in form and details may be made therein without departing from the spirit or scope of the invention as defined by the following claims.

What is claimed is:

1. A display device, comprising:

- an organic emission layer in which a first pixel area, a second pixel area and a third pixel area are defined;
- a color filter layer disposed on the organic emission layer, wherein the color filter layer comprises first to third color filters overlapping the first to third pixel areas,

respectively, wherein the first to third color filters emit first light to third light, respectively, which are different from one another;

a first optical filter layer disposed on the color filter layer, wherein the first optical filter transmits at least one of the first light and the second light, and reflects or absorbs the third light; and

a light-focusing layer disposed between the color filter layer and the organic emission layer, wherein the light-focusing layer comprises first to third light-focusing parts overlapping the first to third pixel areas, respectively,

wherein at least one of the first to third color filters comprises quantum dots.

2. The display device of claim **1**, wherein the first optical filter layer blocks light having a wavelength less than or equal to about 500 nm.

3. The display device of claim **1**, wherein the first optical filter layer overlaps at least one of the first pixel area and the second pixel area.

4. The display device of claim **1**, wherein the first optical filter layer is integrally formed as a single unitary unit, and an opening is defined in the first optical filter at a position overlapping the third pixel area.

5. The display device of claim **1**, wherein a refractive index of the light-focusing layer is in a range from about 1.4 to about 2.5.

6. The display device of claim **1**, wherein a gap between the organic emission layer and the color filter layer is in a range from about 5 μm to about 100 μm .

7. The display device of claim **1**, wherein each of the first to third light-focusing parts comprises a convex lens, a micro-prism, a planar lens, a Fresnel lens, a metamaterial, or a combination thereof.

8. The display device of claim **1**, wherein at least one of the first to third light-focusing parts comprises a convex lens, and a tilting angle of the convex lens is in a range from about 30 degrees to about 90 degrees.

9. The display device of claim **1**, wherein at least one of the first to third light-focusing parts comprises a micro-prism, and a tilting angle of the micro-prism is in a range from about 20 degrees to about 80 degrees.

10. The display device of claim **1**, wherein a width of each of the first to third light-focusing parts is larger than a width of a corresponding one of the first to third pixel areas.

11. The display device of claim **1**, wherein at least two of each of the first to third light-focusing parts are disposed to overlap a corresponding pixel area.

12. The display device of claim **1**, wherein each of the first to third pixel areas of the organic emission layer emits the first light.

13. The display device of claim **1**, wherein a width of each of the first to third color filters is the same as a width of a corresponding one of the first to third pixel areas.

14. The display device of claim **1**, further comprising: a second optical filter layer disposed between the color filter layer and the organic emission layer, wherein the second optical filter layer transmits the third light and reflects at least one of the first light and the second light.

15. The display device of claim 14, wherein the second optical filter layer reflects light having a wavelength greater than about 500 nm.

16. The display device of claim 14, further comprising:
a sealing layer disposed between the second optical filter layer and the light-focusing layer and having a refractive index lower than a refractive index of the light-focusing layer.

17. The display device of claim 1, wherein
the first light is a red light,
the second light is a green light, and
the third light is a blue light.

* * * * *

专利名称(译)	显示装置		
公开(公告)号	US20190371866A1	公开(公告)日	2019-12-05
申请号	US16/424729	申请日	2019-05-29
[标]申请(专利权)人(译)	三星电子株式会社		
申请(专利权)人(译)	SAMSUNG ELECTRONICS CO., LTD.		
当前申请(专利权)人(译)	SAMSUNG ELECTRONICS CO., LTD.		
[标]发明人	KIM TAE GON LEE SUNG HUN JUN SHIN AE CHUNG DEUKSEOK		
发明人	KIM, TAE GON LEE, SUNG HUN JUN, SHIN AE CHUNG, DEUKSEOK		
IPC分类号	H01L27/32 G02B5/20 G02B3/00 H01L51/52		
CPC分类号	H01L27/322 H01L51/5253 H01L51/5275 G02B5/201 H01L2251/5369 G02B3/00		
优先权	1020180061208 2018-05-29 KR		
外部链接	Espacenet USPTO		

摘要(译)

显示装置包括：有机发光层，其中限定了第一像素区域，第二像素区域和第三像素区域；滤色器层，其设置在有机发射层上并且包括与第一至第三像素重叠的第一至第三滤色器。在第一至第三滤色器分别向第一光至第三光发射区域的区域，第一滤光器层设置在滤色器层上并且透射第一光和第二光中的至少一个并反射或吸收光。第三光；以及聚光层，其设置在滤色器层和有机发光层之间，并且包括分别与第一至第三像素区域重叠的第一至第三聚光部分，其中第一至第三滤色器中的至少一个包括量子点。

